

CONSTRUCTION DESIGN OF LIFTING SPREADER FOR LIFTING HARP EVAPORATOR USING FINITE ELEMENT METHOD

Hammad M. Imad¹, Priyo A. Setiawan^{2*}, Widya E. Primaningtyas¹

*E-mail Korespondensi: priyo.as@ppns.ac.id

¹Design and Manufacture Engineering Study Program, Department of Marine Engineering
Politeknik Perkapalan Negeri Surabaya, Indonesia

²Piping Engineering Study Program, Department of Marine Engineering
Politeknik Perkapalan Negeri Surabaya, Indonesia

ABSTRAK

Sebuah perusahaan yang bergerak di bidang EPCC sedang mengerjakan proyek penggantian elemen tube evaporator pada sebuah HRSG. Alat angkat dibutuhkan untuk proses pengangkatan elemen yang meliputi proses pengangkatan secara vertikal dan horizontal, desain dan perhitungan komponen pada spreader bar harus diperhitungkan dengan baik, komponen spreader bar meliputi main profile, sling, shackle & padeye. Hal ini dilakukan agar tidak terjadi kecelakaan kerja yang fatal baik bagi pekerja, material yang diangkat, pesawat angkat maupun spreader bar. Perhitungan komponen-komponen alat bantu angkat dilakukan untuk mengetahui dimensi komponen yang akan digunakan, kemudian juga menghitung tegangan von mises yang terjadi. Penelitian ini bertujuan untuk merampingkan alat bantu angkat yang sebelumnya berjumlah 2 spreader bar menjadi 1 spreader bar tanpa mengurangi kekuatan struktur. Hasil perhitungan von mises stress yang terjadi pada posisi vertikal sebesar 68.89 Mpa (FEM Validasi = 29.16 Mpa), dengan tegangan ijin sebesar 83.3 Mpa, sedangkan pada posisi horisontal von mises stress yang terjadi sebesar 30.92 Mpa (FEM = 17.12 Mpa).

Kata Kunci: Metode Elemen Hingga, Alat Bantu Angkat, HRSG

ABSTRACT

A company engaged in EPCC is working on a project to replace the evaporator tube element in an HRSG. Lifting equipment is needed for the element lifting process which includes vertical and horizontal lifting processes, the design and calculation of components on the spreader bar must be calculated properly, the spreader bar components include the main profile, sling, shackle & padeye. This is done so that there are no fatal work accidents for either the worker, the material being lifted, the lift plane or the spreader bar. Calculation of the components of the lifting aid is carried out to determine the dimensions of the components to be used, then also calculate the von mises stress that occurs. This study aims to streamline the lifting equipment which previously amounted to 2 spreader bars to 1 spreader bar without reducing the strength of the structure. The results of the calculation of von mises stress that occurred in the vertical position amounted to 68.89 Mpa (FEM Validation = 29.16 Mpa), with an allowable stress of 83.3 Mpa, while in the horizontal position the resulting von mises stress was 30.92 Mpa (FEM = 17.12 Mpa).

Keywords: Finite Element Method, Lifting Appliances

INTRODUCTION

Indonesian or foreign companies engaged in fabrication services and power plant maintenance services are companies that produce components in power plants such as Evaporator, Superheater, Reformer, Co-Boiler, Steel Structure, and Ducting, as well as serving the installation of these components or On-Site Services. PT X is a company engaged in fabrication and installation services in the field that is currently carrying out fabrication and installation work on the evaporator harp on HRSG X. The work process includes fabrication in the workshop, shipping, material handling, fit up, welding, and finishing. Material handling is a critical process,

such as the harp evaporator tube handling process which is prone to warping and risks the tube becoming dented and will lose its integrity if the lifting process is without the use of a spreader bar. The evaporator is one of the element pressure parts with a finned tube arrangement resembling a harp containing fluid inside, the damage experienced by the evaporator is corrosion experienced by the pipe, so it needs to be replaced so that the HRSG can function optimally, after the Evaporator manufacturing process in the workshop. completed, then proceed to the transportation process from the factory to the consumer's place and the installation process is carried out. In this installation process, careful material handling is required using the help

of mobile cranes and forklifts. Because safety is very influential when lifting, if the slightest problem occurs such as a broken sling will have fatal consequences. Manufacturing costs, materials, crane use and even worker safety are top priorities. The existing structure in the lifting process must not be damaged or overstressed. The installation of spreader bars makes it easier to lift the harp evaporator from the trailer to the laydown area and from the laydown area to the monorail fit up. The design and layout of the spreader bar must be designed appropriately as this affects the level of stress experienced by the harp evaporator. The related components in the spreader bar also need to be considered starting from the sling, shackle & padeye design. Current conditions in the evaporator element replacement project at PT.X, in the evaporator replacement process, 2 types of spreader bars are needed for 2 types of lifting, namely horizontal and vertical lifting, horizontal lifting is the process of lowering material from the truck to the factory area, while vertical lifting is lifting from the factory area to the installation area. There are numerical methods by using the computational fluid dynamics like turbine rotation (Setiawan et al, 2018), (Yuqa et al, 2019), (Setiawan et al, 2020), (Subekti et al, 2020), (Setiawan et al, 2021), (Sectio et al, 2022), (Setiawan et al, 2023), Manual calculation and validation using the finite element method, this research offers a spreader bar that can be used simultaneously for vertical and horizontal lifting in the hope of reducing spreader bar production costs.

MATERIALS AND METHOD

This section will discuss the primary literature review supporting this article, as well as the research methods.

Product Redesign

Existing products are frequently redesigned to create new products. Product redesign has become an evolutionary strategy in product development (Juniani et al, 2022; Zhang et al., 2019). The primary objective of product redesign is to increase customer contentment by enhancing selected target features. Consequently, identifying product features that will be improved is an essential aspect of product redesign research. These enhanced product features are implemented through product redesign to increase customer satisfaction and adapt to changing customer requirements. In recent years, identifying product features that should be enhanced or redesigned has become an essential area of study to increase product quality and decrease manufacturing costs.

Autodesk Fusion 360

Autodesk Fusion 360 is an all-encompassing 3D computer-aided design (CAD), computer-aided engineering (CAE), and computer-aided manufacturing (CAM) application. It is frequently used for product development and prototyping by engineers, designers, and manufacturers (Rahman et al., 2020; Sholeh et al., 2018). The research used the fusion 360 in the deflection (Ningtyas et al, 2023). The design method used the Ulrich method by creating design concepts, then will be selected the best design according to the selection criteria in terms of functionality, strength, and cost, and analysis of structural strength with manual calculation and simulation using Autodesk Fusion 360 software (devi et al, 2022).

Fusion 360 provides various practical tools and capabilities that facilitate product redesign Included are:

- a. Fusion 360 enables the creation of parametric 3D models. This model indicates that the design is readily modifiable by adjusting dimensions, angles, and features. Modifications can be made swiftly and efficiently, allowing for an efficient product redesign.
- b. **Collaboration and Version Control.** Fusion 360 provides cloud-based tools enabling multiple team members to collaborate on a project simultaneously. Additionally, it includes version control capabilities, enabling users to monitor and manage design iterations. This facilitates collaboration and streamlines the product redesign, particularly in a team setting.
- c. **Simulation and Analysis.** Fusion 360 incorporates robust simulation and analysis tools that allow engineers to assess the redesigned product's performance, structural integrity, and behaviour. It can simulate various conditions and forces, allowing for the identification of potential flaws or areas for enhancement prior to production.
- d. Fusion 360 provides realistic rendering and visualization capabilities, enabling designers to generate high-quality visual representations of the redesigned product. This helps stakeholders and clients better comprehend the proposed changes and make informed decisions regarding the redesign.
- e. **Manufacturing and CAM Integration:** Fusion 360 supports computer-aided manufacturing (CAM) capabilities, allowing for a smooth transition from design to production. It contains tools for generating toolpaths, simulating machining operations, and producing machine code for CNC (Computer Numerical Control) machinery. This

integration ensures that the redesigned product can be efficiently produced.

Overall, Autodesk Fusion 360 offers a robust set of tools and features to facilitate the product redesign process. It streamlines the entire design-to-manufacturing workflow, enabling designers and engineers to create, modify, simulate, and visualize their redesigned products efficiently.

Research Method

The research article starts with performing a literature review, including a gap to study the topic in question. This article’s objectives were created after research problem defined. Then, the designing and modeling of spreader bar were performed by utilizing Fusion 360 for design optimization. First, the product redesign is modeled using computer-aided design to create a 3D model. Moreover, Finite Element Method (FEM) simulation requires a mesh generation to numerically model the spreader bar after the data are selected and inputted to the solver. At the next stage, the loading and boundary conditions are needed to be defined before the FEM is performed. The obtained results are verified to ensure the generated results from the FEM method.

Data Collecting

In this study, the data collection method The data collection method is carried out by collecting drawings of existing models and data from evaporators that will be fabricated is data that has been approved by the customer, the data includes dimensions, loads and materials. After the harp evaporator data and the existing spreader bar are obtained.

The overall research flowchart is portrayed in Figure 1.

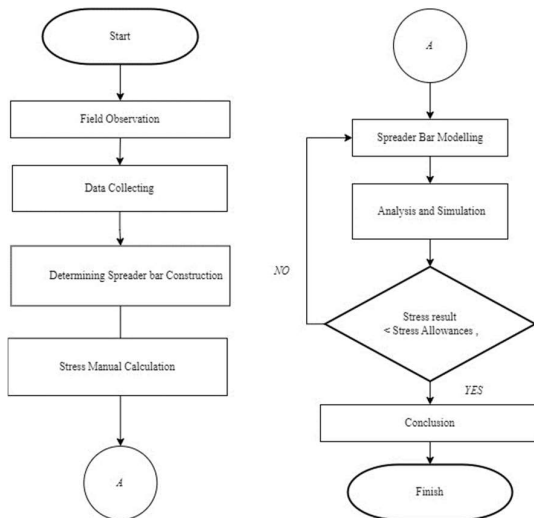

Figure 1. Research Method

RESULT AND DISCUSSION

Fusion 360 allows for the import of geometric models created by CAD to perform finite element analysis on static structures, dynamic features, etc. DFR analysis will be performed by structural analysis via Fusion 360. The driven optimization feature can generate analysis and optimization for deterministic designs. A typical analysis feature is the model’s size, such as volume, moment of inertia, clearance, etc. Product design exploration will provide performance analysis for design optimization based on the results of the analysis of several parts of the design to find design variable values.

Profile of Spreader bar

In this part will discuss the calculation of the lifting pressure vessel in detail. The data collection stage is the first step in this research. The data obtained is company X data. Consists of data about the evaporator to be lifted and also the required spreader bar length design data.

Harp Evaporator

- Length = 13095 mm
- Width = 1940 mm
- Life Load = 3.07 Tons

Spreader Bar

- Length = 12595 mm
- Width = 2070 mm
- Life Load = 0.7 Tons

Profile of Spreader bar

The calculation of the overall force is intended to determine the force acting on each sling, so that the range of resistance forces carried on the structure can be known. The following is the force distribution in the vertical position as shown in Figure 1 below

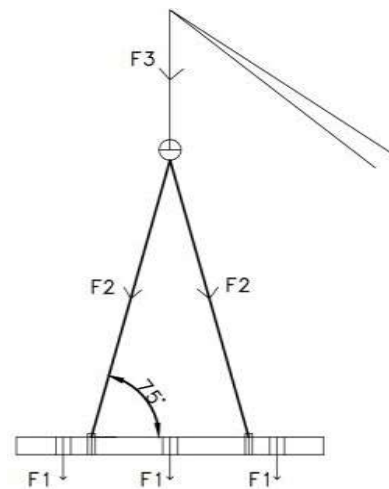

Figure 2. Fit body diagram vertical

$$\begin{aligned}
 W_{\text{total}} &= \text{Total weight (N)} \\
 m &= \text{mass (kg)} \\
 g &= \text{gravity (9.806 m/s}^2)
 \end{aligned}$$

$$\begin{aligned}
 W_{\text{total}} &= m \times g \\
 &= 3770 \text{ kg} \times 9.806 \text{ m/s}^2 \\
 &= 36,968.62 \text{ N}
 \end{aligned}$$

$$\begin{aligned}
 F_{ay} &= F \sin (\alpha) \\
 &= 18484.31 \text{ N} \sin (75) \\
 &= 17811.68 \text{ N}
 \end{aligned}$$

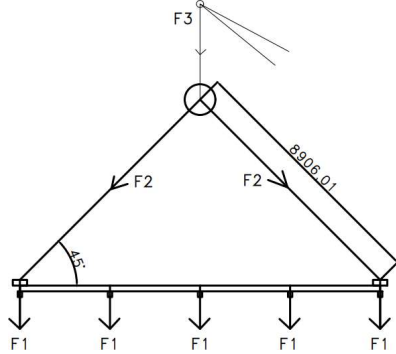

Figure 3. Fit body diagram horizontal

Figure 2 shows the force distribution in the horizontal lifting process with the following force calculation:

$$W_{\text{total}} = \text{Total weight (N)}$$

$$M = \text{mass (kg)}$$

$$G = \text{gravity (9.806 m/s}^2)$$

$$\begin{aligned}
 W_{\text{total}} &= m \times g \\
 &= 3770 \text{ kg} \times 9,806 \text{ m/s}^2 \\
 &= 36.968,62 \text{ N}
 \end{aligned}$$

$$\begin{aligned}
 W_{\text{sling}} &= 36.968,62 \text{ N} / 4 \\
 &= 9242,155 \text{ N}
 \end{aligned}$$

$$\begin{aligned}
 F_{2y} &= F \sin (\alpha) \\
 &= 9242,155 \text{ N} \sin (45) \\
 &= 7.864,182 \text{ N}
 \end{aligned}$$

$$\begin{aligned}
 F_{1xy} &= (\text{Evaporator mass} \times \text{gravity}) / 10 \\
 &= (3070 \text{ kg} \times 9.8 \text{ m/s}^2) / 10 \\
 &= 3008,6 \text{ N}
 \end{aligned}$$

Determining Spreader bar

In determining the design of a spreader bar profile beam, there are steps that must be taken in order to create a design that is feasible to implement or use, including the main components in the design of the lifting appliance for the lifting of this harp evaporator, the components include the H-beam profile, padeye, stiffener plate and bracing. These components include the H-beam profile, padeye, stiffener plate and bracing.

$$\text{Span} = 12597 \text{ mm}$$

$$\text{Safety working load (SWL)} = 4000 \text{ kg}$$

$$\text{Material} = \text{ASTM A36}$$

$$\text{Yield strength} = 250 \text{ N/mm}^2$$

$$\text{Modulus young (E)} = 200000 \text{ N/mm}^2$$

The summary of the moment of inertia bar calculations is shown in Table 1 below.

Table 1. Profile Specification

Section index	Modulus Inertia profile		Modulus section Profile	
	Ix mm ⁴	Iy mm ⁴	Zx mm ³	Zy mm ³
125 x 125	8470000	2930000	136000	47000

Calculation of Stress value of spreader bar in vertical position

The normal stress value of the spreader bar can be obtained using the bending moment obtained from the bending moment before loading by the weight of the spreader bar profile construction plus the bending moment after loading by the weight of the evaporator element, for previously known data can be seen in Table 2

Table 2. Known data values

P	=	17811,68	N
l	=	2070	Mm
q	=	0,2332	N/mm
Ix	=	8470000	mm ⁴
Zx	=	136000	mm ³
Q	=	179294.5	mm ³

For the maximum bending moment bending moment calculation formula (Mmax) using the following equation (Radenko et al., 1966).

$$M_{\text{max}} = \frac{p \times l}{4} + \frac{q \times l^2}{4}$$

$$M_{\text{max}} = 9217544,44 \text{ N} \cdot \text{mm} + 124911 \text{ N} \cdot \text{mm}$$

$$M_{\text{max}} = 9342455,45 \text{ N} \cdot \text{mm}$$

After obtaining the Mmax value. The normal stress value can be found with the following equation:

$$\begin{aligned}
 \sigma &= \frac{M_{\text{max}}}{Z_x} \\
 \sigma &= \frac{9342455,45 \text{ N} \cdot \text{mm}}{136000 \text{ mm}^3} \\
 \sigma &= 68.7 \text{ N/mm}^2
 \end{aligned}$$

The normal stress value obtained is 68,7 N/mm², because the spreader bar has a shear stress that occurs, the shear stress that occurs is calculated

using the following equation formula (Ferdinand et al., 2012).

$$r = \frac{Q.V}{I_x.t}$$

$$r = 3.016327046 \text{ N/mm}^2$$

The shear stress value obtained is 3.016327046 N/mm². Calculating the accumulated stress using the von mises formula to find out the maximum stress that occurs in the spreader bar can use the equation formula as follows :

$$r = \sqrt{(\sigma_t + \sigma_f)^2 + 3r^2}$$

$$= \sqrt{68.7^2 + 3 \times 3.016327046^2}$$

$$= 68.89 \text{ N/mm}^2$$

After the maximum stress value has been known, it is compared with the allowable stress value to find out the feasibility of planning can use the following equation formula:

$$\sigma_{\text{allowance}} = \frac{\sigma_y}{(\text{Sf. k})}$$

$$\sigma_{\text{allowance}} = \frac{250}{(3)} = 83.3 \text{ MPa}$$

with:

- $\sigma_{\text{allowance}}$ = Tegangan ijin (Mpa)
- σ_y = Yield Strength (250 Mpa)
- Sf = Safety Factor (3)

So the stress value from the analysis using the software is said to be failed or unsafe if the stress value exceeds 83.3 MPa. The stress for spreader bar is safe because it has a value of 68.89 MPa, which is less than the allowable stress testing.

To validate it, the spreader was tested in the FEM software as shown in Figure 3, the result was 29.16 Mpa < $\sigma_{\text{allowance}}$ (83.3 Mpa), so the stress occurring in the profile is declared safe.

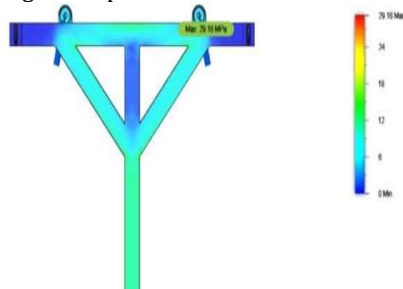

Figure 4. FEM simulation result

Calculation of Stress value of spreader bar in horizontal position.

Calculation of stress value at padeye upper

The normal stress value of the spreader bar can be obtained using the bending moment obtained from the bending moment before loading by the weight of the spreader bar profile construction plus the bending moment after loading by the weight of the evaporator element, for previously known data can be seen in Table 3.

Table 3. Known data values

P	=	7864,18	N
l	=	2070	Mm
q	=	0.2332	N/mm
I _x	=	8470000	mm ⁴
Z _x	=	136000	mm ³
Q	=	179294.5	mm ³

For the maximum bending moment bending moment calculation formula (Mmax) using the following equation

$$M_{\text{max}} = \frac{p \times l}{4} + \frac{q \times l^2}{4}$$

$$M_{\text{max}} = 4069714.23 \text{ N.mm} + 124911 \text{ N.mm}$$

$$M_{\text{max}} = 4194625.23 \text{ N.mm}$$

After obtaining the Mmax value. The normal stress value can be found with the following equation (Radenko et al., 1966):

$$\sigma = \frac{M_{\text{max}}}{Z_x}$$

$$\sigma = \frac{4194625.23 \text{ N.mm}}{136000 \text{ mm}^3}$$

$$\sigma = 30.84 \text{ N/mm}^2$$

The normal stress value obtained is 30.84 N/mm², because the spreader bar has a shear stress that occurs, the shear stress that occurs is calculated using the following equation formula (Ferdinand et al., 2012):

$$r = \frac{Q.V}{I_x.t}$$

$$r = 1.331763475 \text{ N/mm}^2$$

The shear stress value obtained is 1.331763475 N/mm². Calculating the accumulated stress using the von mises formula to find out the maximum stress that occurs in the spreader bar can use the equation formula as follows:

$$r = \sqrt{(\sigma_t + \sigma_f)^2 + 3r^2}$$

$$= \sqrt{30.8423^2 + 3 \times 1.331763475^2}$$

$$= 30.92 \text{ N/mm}^2$$

After the maximum stress value has been known, it is compared with the allowable stress value to find out the feasibility of planning can use the following equation formula:

$$\sigma_{\text{allowance}} = \frac{\sigma_y}{(\text{Sf. k})}$$

$$\sigma_{\text{allowance}} = \frac{250}{(3)} = 83.3 \text{ MPa}$$

with:

- $\sigma_{\text{allowance}}$ = Tegangan ijin (Mpa)
- σ_y = Yield Strength (250 Mpa)
- Sf = Safety Factor (3)

So the stress value from the analysis using the software is said to be failed or unsafe if the stress value exceeds 83.3 MPa. The stress for spreader bar is safe because it has a value of 30.92 MPa, which is less than the allowable stress testing.

To validate it, the spreader was tested in the FEM software as shown in Figure 4, the result was 17.12 Mpa < σ_{ijin} (83.3 Mpa), so the stress occurring in the profile is declared safe.

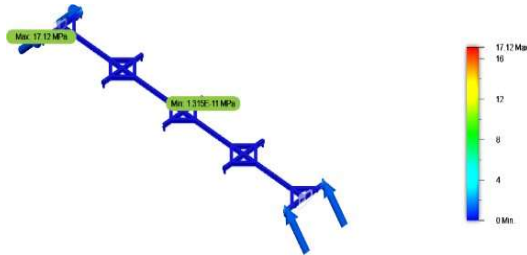

Figure 5. FEM simulation result

Calculation of stress value at padeye lower

The normal stress value of the spreader bar can be obtained using the bending moment obtained from the bending moment before loading by the weight of the spreader bar profile construction plus the bending moment after loading by the weight of the evaporator element, for previously known data can be seen in Table 4.

Table 4. Known data values

P	=	3008.6	N
l	=	2070	Mm
q	=	0,2332	N/mm
I_x	=	8470000	mm ⁴
Z_x	=	136000	mm ³
Q	=	179294,5	mm ³

For the maximum bending moment bending moment calculation formula (M_{max}) using the following equation.

$$M_{max} = \frac{p \times l}{4} + \frac{q \times l^2}{4}$$

$$M_{max} = 1556950.5 \text{ N. mm} + 124911 \text{ N. mm}$$

$$M_{max} = 1681861.5 \text{ N. mm}$$

After obtaining the M_{max} value. The normal stress value can be found with the following equation :

$$\sigma = \frac{M_{max}}{Z_x}$$

$$\sigma = \frac{1681861.5 \text{ N. mm}}{136000 \text{ mm}^3}$$

$$\sigma = 12.36 \text{ N/mm}^2$$

The normal stress value obtained is 12.36 N/mm² , because the spreader bar has a shear stress that occurs, the shear stress that occurs is calculated using the following equation formula:

$$r = \frac{Q.V}{I_x . t}$$

$$r = 0.509492735 \text{ N/mm}^2$$

The shear stress value obtained is 0.509492735 N/mm². Calculating the accumulated stress using the von mises formula to find out the maximum stress that occurs in the spreader bar can use the equation formula as follows:

$$r = \sqrt{(\sigma_t + \sigma_f)^2 + 3r^2}$$

$$= \sqrt{12.87^2 + 3 \times 0.509^2}$$

$$= 3.69 \text{ N/mm}^2$$

After the maximum stress value has been known, it is compared with the allowable stress value to find out the feasibility of planning can use the following equation formula (AISC et al., 2005):

$$\sigma_{allowance} = \frac{\sigma_y}{(Sf. k)}$$

$$\sigma_{allowance} = \frac{250}{(3)} = 83.3 \text{ MPa}$$

with:

- $\sigma_{allowance}$ = Tegangan ijin (Mpa)
- σ_y = Yield Strength (250 Mpa)
- Sf = Safety Factor (3)

So the stress value from the analysis using the software is said to be failed or unsafe if the stress value exceeds 83.3 MPa. The stress for spreader bar is safe because it has a value of 3.69 MPa, which is less than the allowable stress testing.

To validate it, the spreader was tested in the FEM software as shown in Figure 5, the result was 14.98 Mpa < $\sigma_{allowance}$ (83.3 Mpa), so the stress occurring in the profile is declared safe.

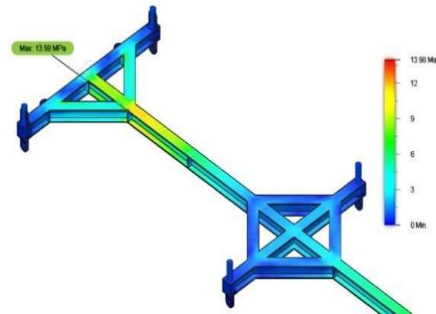

Figure 6. FEM simulation result

CONCLUSION

The conclusions of this spreader bar design research it has 2 result with different method, the stress is obtained which is divided into 2, the stress when vertical and horizontal position, for vertical stress the manual calculation results obtained are 68.89 MPa while for the results of the FEM validation the stress that occurs is 29.16 Mpa, while for horizontal stress the manual calculation results obtained are 30.92 MPa while for the results of the FEM software validation the stress that occurs is 17.12 MPa. The permissible stress is 83.3 MPa. So

that the profile is declared safe because it is less than the maximum allowable stress.

REFERENCE

- American National Standart Institute. (2005). *AISC: Specification for Structural Steel Building*. Chicago: AISC Inc.
- Devi, L. I. P. S. Asmara, P. Sidi. (2022) "Perancangan Pillar Slewing Jib Crane SW1 2 Ton dan Span 5 Meter," *Proceeding 6th Conference on Design and Manufacture Engineering and its Application*.
- Ferdinand, B. (2012), *Mechanics of Materials*, New York: Mcgraw-Hill.
- Juniani, A., Singgih, M., & Karningsih, P. (2022). Proposed Framework of Product Redesign Need Assessment based on Customer Requirement, Complaint and Failure Analysis. *12th Annual International Conference on Industrial Engineering and Operations Management*. <https://doi.org/https://doi.org/10.46254/A N12.20220115>.
- Ningtyas, L. R. M. Hakam, W. E. Primaningtyas. (2023). Analisis Tegangan dan Besar Defleksi pada Wall Jib Crane Kapasitas SWL 1 Ton Menggunakan Metode Elemen Hingga (Studi Kasus PT. Adiluhung Sarasanegara Indonesia), *Proceeding 6th Conference on Design and Manufacture Engineering and its Application*.
- Rudenko, N. (1966). *Mesin Pengangkat*. Jakarta: Erlangga.
- Sectio M. Y. A. (2022) Studi Eksperimen Pengganggu Di Depan Returning Blade Terhadap Performa Turbin Angin Savonius Dengan Penambahan Overlap Ratio. *Diploma Thesis*. PPNS Surabaya.
- Setiawan, P. A. M. Santoso, R. Indarti, N. Ariwiyono, T. Yuwono, and W. A. Widodo. (2021). An Experimental Study of the Savonius Water Current Turbine by means of Myring Equation for $n = 1$. *J. Phys. Conf. Ser.*, vol. 1764, no. 1. Doi: 10.1088/1742-6596/1764/1/012194.
- Setiawan, P. A. R. Indarti, N. Ariwiyono, T. Yuwono, and W. A. Widodo. (2021). An Experimental Study of Overlap Ratio Effect to Savonius water Current Turbine by using Myring Equation for $n=1$," *J. Phys. Conf. Ser.*, vol. 1764, no. 1, doi: 10.1088/1742-6596/1764/1/012198.
- Setiawan, T. Yuwono, and W. Widodo. (2019). Flow Analysis of a Circular Cylinder on the Savonius Hydrokinetic Turbine Performance Placed the Side of Advancing Blade. *Int. J. Mech. Mechatronics Eng. IJMME-IJENS*, vol. 19, no. 06, p. 41
- Setiawan and T. Yuwono. (2018) "The Effect of Inner Fan Blade Angle to The Ventilation Rate of The Turbine Ventilator," *J. Rekayasa Mesin*, vol. 9, no. 3, pp. 227-233. doi: 10.21776/ub.jrm.2018.009.03.10.
- Setiawan, T. Yuwono, and W. A. Widodo. (2021) Flow visualization analysis on the vertical axis Savonius water turbine by placing a cylinder in front of returning by varying stagger angle. *J. Phys. Conf. Ser.*, vol. 1764, no. 1. doi: 10.1088/1742-6596/1764/1/012203.
- Subekti A. Setiawan PA, Bachtiar. (2020). A numerical study of the effect of a single cylinder and plate deflector toward the Savonius wind turbine performance. *J. Phys. Conf. Ser.*, vol. 1477, no. 5. doi: 10.1088/1742-6596/1477/5/052010.
- Setiawan, P. A. T. Yuwono, and W. A. Widodo. (2019) Numerical Study of the Stagger Angle Effect of a Circular Cylinder Installed in front of Returning Blade Toward the Vertical Axis Savonius Water Turbine Performance. *J. Phys. Conf. Ser.*, vol. 1179, no. 1, doi: 10.1088/1742-6596/1179/1/012107.
- Yuqa, O. H., Setiawan PA., Ariwiyono N. (2019). Studi Numerik Pengaruh Variasi Sudut Stagger Silinder Sirkular Pada Sisi Advancing Blade Terhadap Performa Turbin Air Savonius Tipe Myring. *Proceeding 2nd Conference on Marine Engineering and Its Application*. pp. 2-7.
- Zhang, L., Chu, X., & Xue, D. (2019). Identification of the to-be-improved product features based on online reviews for product redesign. *International Journal of Production Research*, 57(8), 2464-2479. <https://doi.org/10.1080/00207543.2018.1521019>